

Titanium Getter Pump [GGT-3/PGT Series]

Titanium getter pumps (PGT-3/GGT series) pass current directly through titanium alloy placed in a vacuum chamber in order to sublimate the titanium. The sublimated titanium creates a large active metallic surface on the surrounding walls for absorbing and removing chemically active gases (H₂, N₂, O₂, H₂O, CO, CO₂).

Since an active metallic surface made of titanium does not absorb inactive gases (He, Ne, Ar, CH₄, C₂H₆, and other organic gases), these units are used in combination with such equipment as sputter ion pumps and turbo molecular pumps.



GGT-3

PGT-3F

Features

- ▶ **Ultimate Pressure is Improved due to High Pumping Speed**
An absorbing surface of sublimated Titanium will improve pumping speed and improve ultimate pressure.
- ▶ **Extended Life Of Filament**
The titanium alloy filaments have a long lifespan. One filament lasts approximately 75 hours with continuous operation (30 seconds of current /60 seconds at rest) and approximately 25 hours with continuous current.
- ▶ **Bake-out**
Because metal seals are used on the flanges, bake out temperatures of 250°C can be achieved.
- ▶ **Ultra High Vacuum**
A proprietary surface treatment of all structural surfaces has been performed for high vacuum conditions.

Applications

- ▶ Vacuum systems capable of high vacuum from atmospheric pressure.
- ▶ Vacuum systems for various deposition system such as vapor deposition and sputtering, etc.
- ▶ Vacuum systems for many research and development projects.

Accessories

- ▶ Output cable 3 m (single prong) *2
- ▶ Input cable 5 m (3 prong) *1
- ▶ Operation manual *1

Options

- ▶ Titanium filament : 6 set (for both PGT-3F and 6F)
- ▶ Electrode cover : SUS
- ▶ Output cable : 5, 10 m
- ▶ 250°C Heat resistant output cable : 3,5,10m (PFA wire)

Titanium Getter Pump [GGT-3/PGT Series]

Specifications

Model	PGT-3F	PGT-6F	Model	GGT-3
Pumping speed *1	24m ³ /s·m ² (20°C, 68°F)	64m ³ /s·m ² (-196°C, -320°F)	Output	Variable AC0 to 6V, maximum 60A
Applicable pressure range	Ultra high vacuum range of 10 ⁻¹ to 10 ⁻⁹ Pa (10 ⁻³ to 10 ⁻¹¹ Torr-mbar)		Control method	ON/OFF control by time
Applicable gases	H ₂ , N ₂ , O ₂ , H ₂ O, CO, CO ₂		Timer setting range	0.05 seconds to 300hours (for both ON and OFF)
Inapplicable gases	He, Ne, Ar, CH ₄ , C ₂ H ₆ , other organic gases		Output display	Output current display
Leak volume	1.3×10 ⁻¹¹ Pa·m ³ /s (1.7×10 ⁻¹² Torr-L/sec, 1.3×10 ⁻¹² mbar-L/sec) or less		Output display gradations	Analog display/60A full scale
Baking temperature	250°C (482°F)		Interlock input	1point
Power consumption	270W		Allowable surrounding temperature	5 to 40°C (41 to 104°F)
Filament material	Titanium alloy		Voltage frequency	Single phase AC200 to 220V, 50/60 Hz selectable frequency
Filament lifespan	Standard continuous *2 : Approx. 75 hours per filament, continuous current: Approx. 25 hours per filament		Current	3.5A maximum
Number of filament	3	6	Weight	12kg
Connection flange *3	UFC070-FH	UFC114-FH		
Weight	1.0kg	2.5kg		

*1 Calculated in ultra high vacuum pressure region using nitrogen and a temperature of 20°C (68°F).

*2 Cycle containing 30 seconds of current at 270 W and 60 seconds of rest.

*3 ULVAC standard stainless steel knife-edge metal seal flange. (ICF corresponding)

Dimensions

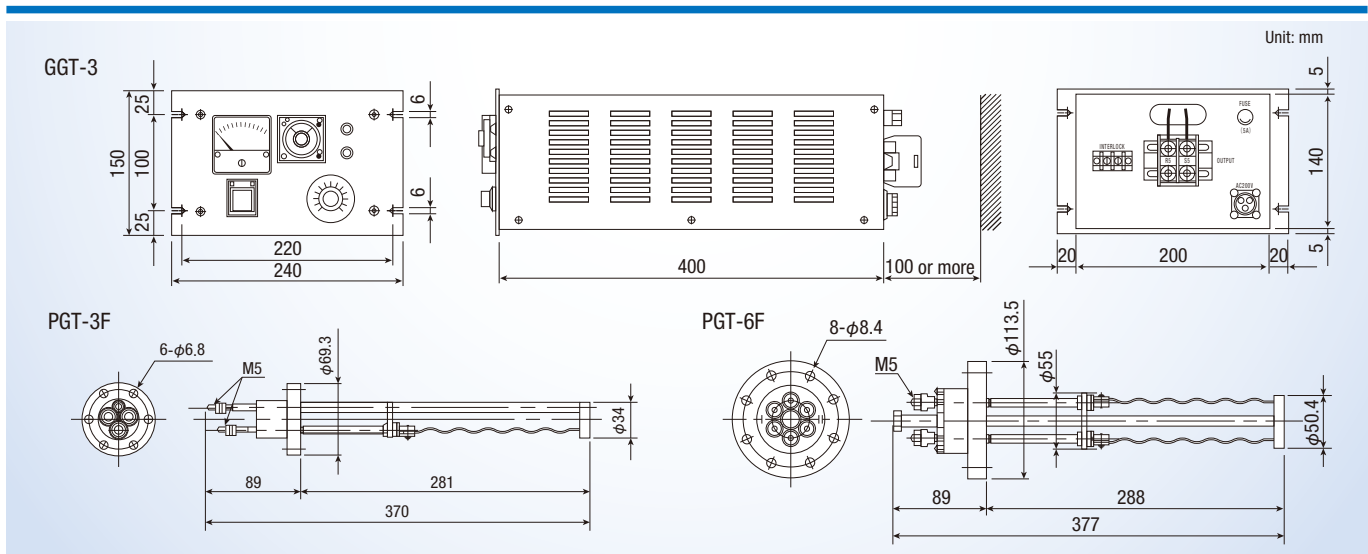

Characteristic Pumping Speeds for Various Gases When Using Fresh Titanium Deposition Film Surface

Getter surface temperature	Gas type								
	H ₂	N ₂	O ₂	CO	CO ₂	H ₂ O	CH ₄	Ar	He
Chamber temperature (20°C, 68°F)	24	24	16	48	40	32	N.A.	N.A.	N.A.
Liquid nitrogen temperature (-196°C, -320°F)	64	64	N.A.	110	92	140	N.A.	N.A.	N.A.

Unit: m³/(s·m²)

Pumping Speed Curve

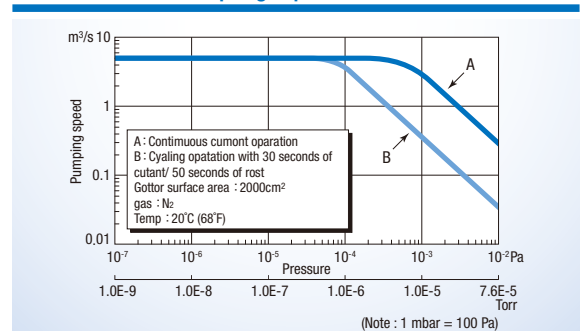

ULVAC, Inc. Components Division

www.ulvac.co.jp/eng

Overseas Sales in Japan TEL +81-467-89-2261

USA : ULVAC Technologies, Inc. TEL +1-978-686-7550
 GERMANY : ULVAC GmbH TEL +49-89-960909-0
 CHINA : ULVAC (SHANGHAI) Trading Co.,Ltd. TEL +86-21-6127-6618
 TAIWAN : ULVAC TAIWAN, Inc. TEL +886-3-579-5688
 KOREA : ULVAC KOREA, Ltd. TEL +82-31-683-2922
 SINGAPORE : ULVAC SINGAPORE PTE LTD TEL +65-6542-2700

PHILIPPINES : ULVAC Singapore Philippines Branch TEL +63-2-828-7700
 VIETNAM : ULVAC Singapore Vietnam Representative Office TEL +84-8-62556762
 THAILAND : ULVAC (THAILAND) LTD TEL +66-2-312-4447
 MALAYSIA : ULVAC MALAYSIA SDN. BHD. TEL +60-3-5121-4700
 INDIA : ULVAC, Inc., India Branch TEL +91-40-27007006

► This catalog is subject to change without notice.
 ► This catalog is published in order to sell this product in overseas. Please see Japanese catalog when purchasing in Japan.